

the digital group

po box 6528 denver, colorado 80206 (303) 777-7133

MINI FLOPPY DRIVE MANUAL

Copyright © 1988
Digital Equipment Corporation
All rights reserved. This manual
contains information that is
proprietary to Digital Equipment Corporation.

Note: Orders pertaining to Mini-floppy Controller Cards

Instructions for modifying the standard controller card to run with mini-floppy drives have only been incorporated into the mini-floppy cabinet documentation which has been provided. These instructions detail resistor changes as well as cabling changes required to run floppy drives in a Digital Group system.

Before building the floppy controller card go through the mini-floppy cabinet documentation and note all pertinent changes.

the digital group

po box 6528 denver, colorado 80206 (303) 777-7133

MICRO PERIPHERALS INC.

MPI Flexible Disk Series B51/B52

PRODUCT MANUAL

TABLE OF CONTENTS

	Page
<u>SECTION 1</u>	
1.0 INTRODUCTION.....	1
1.1 GENERAL.....	1
 <u>SECTION 2</u>	
2.0 INSTALLATION AND CHECKOUT.....	5
2.1 SCOPE.....	5
2.2 UNPACKING.....	5
2.3 INSTALLATION.....	5
2.4 INPUT/OUTPUT CABLE.....	5
2.5 D.C. POWER.....	6
2.6 INITIAL CHECKOUT.....	6
 <u>SECTION 3</u>	
3.0 INTERFACING REQUIREMENTS.....	7
3.1 INPUT LINES.....	7
3.1.2 Line Termination.....	7
3.1.3 Drive Select 1 to 3.....	8
3.1.4 Motor On.....	8
3.1.5 Direction Select.....	8
3.1.6 Step.....	8
3.1.7 Write Gate.....	8
3.1.8 Write Data.....	10
3.1.9 Head Select (B52 Only).....	10
3.1.10 Drive Select 4 (Optional Feature).....	10
3.2 OUTPUT LINES.....	10
3.2.1 Track 00 (Optional).....	10

TABLE OF CONTENTS (Continued)

	Page
3.2.3 Index/Sector.....	11
3.2.4 Write Protect.....	11
3.2.5 Read Data.....	11
 <u>SECTION 4</u>	
4.0 OPERATION.....	19
4.1 GENERAL.....	19
4.2 OPERATING INSTRUCTIONS.....	19
4.2.1 Flexible Diskette Loading.....	19
4.2.2 Flexible Diskette Removal.....	19
4.3 DISKETTE HANDLING RECOMMENDATIONS.....	19
 <u>SECTION 5</u>	
5.0 THEORY OF OPERATION.....	21
5.1 GENERAL.....	21
5.1.1 Diskette Spindle Drive.....	21
5.1.2 Head Load Actuator.....	21
5.1.3 Head Positioning.....	21
5.1.4 Safety and Control Electronics.....	22
5.1.5 Read/Write Head.....	22
5.1.6 Stepper Motor.....	22
5.1.7 Write Operation.....	23
5.1.8 Read Operation.....	23
5.1.9 Index Pulse Generation.....	23
 <u>SECTION 6</u>	
6.0 ERROR RECOVERY.....	24

TABLE OF CONTENTS (Continued)

	Page
6.1 SEEK ERRORS.....	24
6.2 WRITE ERRORS.....	24
6.3 READ ERRORS.....	24

SECTION 7

BLOCK DIAGRAM.....	25
--------------------	----

SECTION 8

8.0 MAINTENANCE.....	28
8.1 CLEANING READ/WRITE HEAD.....	28
8.2 ADJUSTMENT PROCEDURES.....	28
8.2.1 Radial CE Alignment.....	28
8.2.2 Index to Data Alignment.....	29
8.2.3 Track 00 Sensor.....	29
8.2.4 Speed Control.....	29
8.2.5 Track 00 End Stop.....	30

APPENDIX A

SPARE PARTS LIST - MODELS B51/B52.....	32
----------------------------------------	----

LIST OF FIGURES

Figure	Title	Page
1	Outline and Mounting Dimensions.....	4
2	Track Access Timing.....	9
3	Read Initiate Timing.....	9
4	Read Signal Timing.....	12
5	Write Initiate Timing.....	12

LIST OF FIGURES (Continued)

Figure	Title	Page
6	Write Data Timing.....	12
7	General Control and Data Timing Requirements....	13
8	Index Sector Timing (Soft Sector).....	14
9	Index Sector Timing (Hard Sector).....	14
10	Connector J2.....	15
11	Connector J1.....	15
12	Interface Signals - B51/52.....	16
13	Shunt Configuration.....	17
14	Write Protect Option.....	18
15	Diskette Orientation.....	20
16	Component Location.....	31

LIST OF TABLES

Table	Title	Page
1-1	Specifications - General/Physical.....	2
1-2	Power Requirements.....	3
1-3	Environmental.....	3
1-4	Data Capacity Unformatted (K Bytes).....	3
3-1	Recommended Connectors - Pl.....	17

SECTION 1

1.0 INTRODUCTION

This manual describes the Series B5X flexible disk drive. The Series B5X is a fast access, high reliability, high accuracy mini-sized flexible disk drive. It uses a band-driven design concept similar to IBM's. It is functionally compatible to the major manufacturers of mini-sized flexible disk drives

1.1 GENERAL

The Series B5X is a flexible disk drive that can store and retrieve information from a 5¼ inch mylar diskette. It provides capability to read and update information on one side or both sides of the diskette in single or double density formats. Utilizing either hard or soft-sectored diskettes, the Series B5X can store from 125K bytes to 500K bytes of data dependent on the model chosen, and the data transfer utilized. The Series B5X is 3.25 x 5.75 x 7.5 inches and weighs only 3 pounds. Very fast and accurate track access is achieved by a band-driven head position system that offers 5 msec track-to-track step rates. The electronics are packaged on a single printed circuit board, 5 x 5 inches, and mounted in a convenient location on the device. A standard IBM type ceramic head is used to perform the Read/Write. The Series B5X is functionally compatible to the standard mini floppy devices, and can Read/Write diskettes formatted by the device in either hard or soft sector modes. The diskette is rotated by a DC servo controlled motor maintaining its rotational speed at 300 rpm \pm 1%.

SPECIFICATIONS

TABLE 1-1

GENERAL

Parameter	Characteristics
Tracks	35 or 40
Track Density	48 TPI
Physical Sectors	1, 10 or 16 with available hard sector media
Rotational Speed	300 rpm $\pm 1\%$
Access Time	
Track-To-Track	5 msec
Average (35 Tracks)	75 msec
Settle Time	15 msec
Average Latency	100 msec
Recording Density	2580 BPI
Data Flux Density	5160, fci
Head Load Time	35 msec
Power Up Delay	1 sec
PHYSICAL	
Height	3.25 inches (8.255 cm)
Width	5.75 inches (14.605 cm)
Length	7.5 inches (19.05 cm)
Weight	3.0 pounds (1.36 kg)

POWER REQUIREMENTS

TABLE 1-2

Power	+12 VDC \pm 5%, 1.5A + 5 VDC \pm 5%, 0.7A
Typical Power Dissipation	15W Operation 6W Standby

ENVIRONMENTAL

TABLE 1-3

Parameter	Characteristics
Operating Temperature	40° to 115°F (4.4°C to 46.1°C)
Relative Humidity	20 to 80% (noncondensing)

DATA CAPACITY UNFORMATTED (K BYTES)

TABLE 1-4

	Single Density (FM)		Double Density (MFM, M ² FM)	
	B51	B52	B51	B52
Track Capacity	3.13	6.26	6.26	12.52
Disc Capacity 35 Tracks	109.375	218.750	218.75	437.50
40 Tracks	125	250	250	500

Bottom View

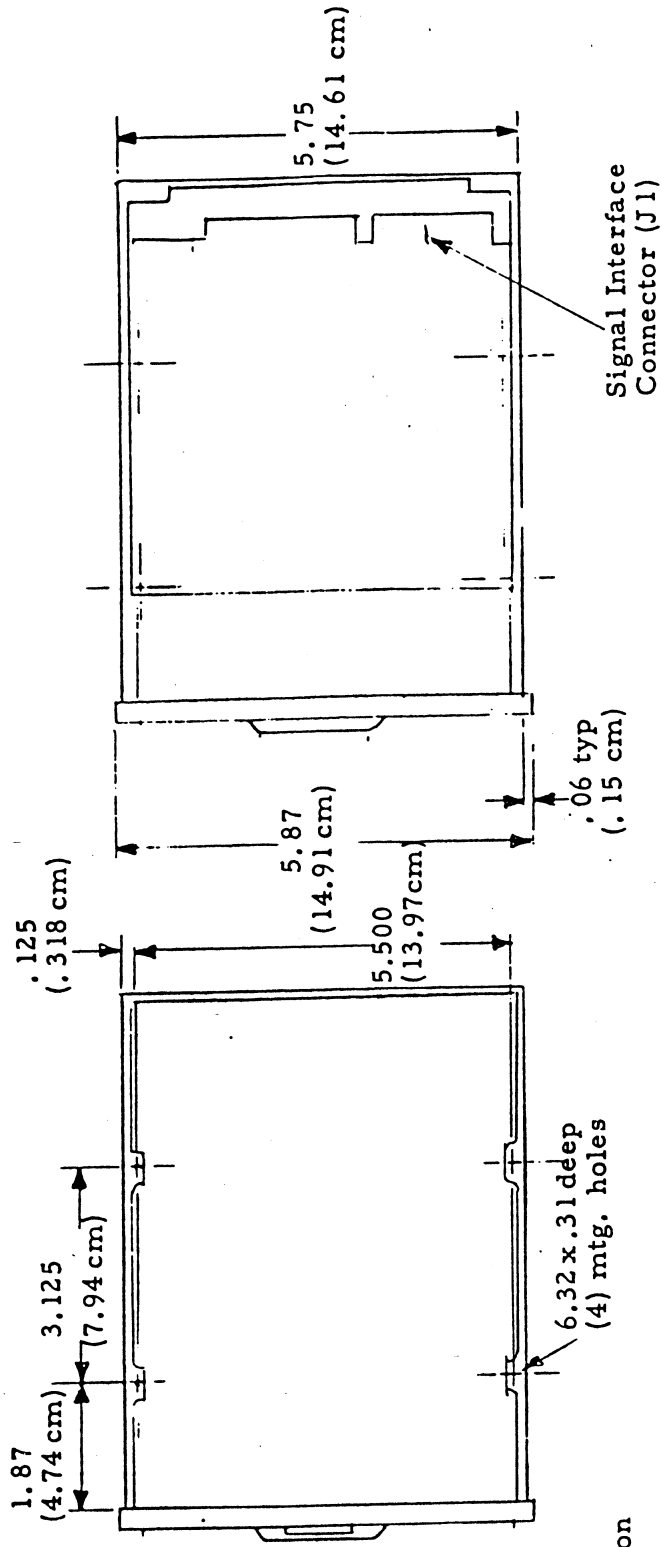

Top View

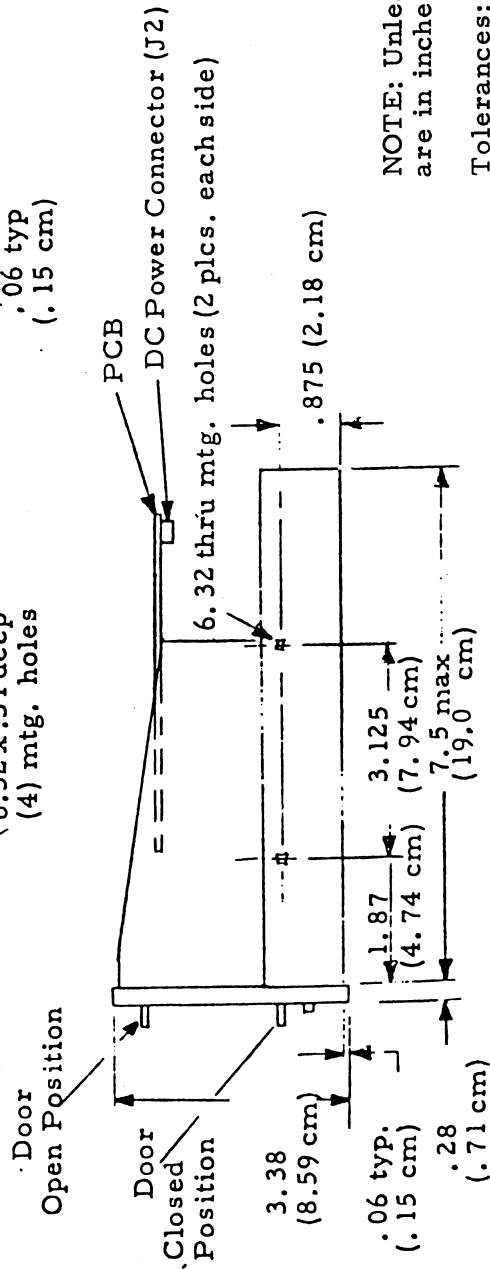

NOTE: Unless otherwise stated dimensions are in inches.

Tolerances: .xxx ± 0.010
 .xx ± 0.020

Side View

Figure 1 Outline and Mounting Dimensions

SECTION 2

2.0 INSTALLATION AND CHECKOUT

2.1 SCOPE

This section provides the information and procedures necessary to place B5X into operation.

2.2 UNPACKING

During unpacking, care must be exercised to insure that all tools are non-magnetic and do not inflict damage to the unit. As the unit is unpacked, inspect it for possible shipping damage. All claims for this type of damage should be filed promptly with the transporter involved.

If a claim is filed for damages, save the original packing material. Most packing material may be reuseable if reasonable care is used in unpacking. Unpack the drive as follows:

1. Remove external packing material carefully.
2. Remove the drive from the container.
3. Remove internal packing materials, following instructions provided on the package.

2.3 INSTALLATION

Due to the small size and light weight, the B5X can be installed or mounted in any convenient location or position. To reduce possible operator errors, mounting in a vertical position is recommended. The drive must be installed in a location that will prevent the I/O cable from exceeding 10 feet in length. Refer to Figure 1 for dimensions and mounting provisions.

2.4 INPUT/OUTPUT CABLE

The I/O cable is an optional item and is supplied on order. Refer to Table 3-1 for cable connector part number and attachment. The maximum cable length from connector to connector is 10 feet. All inputs and

outputs are paired, one line for function, one for ground. Characteristic impedance should be approximate 130 ohms. The I/O cable connector is included as an option. The connector option consists of a self keyed connector with associated clamp. Figure 12 provides information relative to the connector pin/signal assignments for I/O cable.

2.5 D.C. POWER

D.C. power to the drive is via connector P2/J2, which is located on the non-component side of the PCB near the spindle motor. The drive uses +12V D.C. and +5V D.C. Table 1-2 outlines the voltage and current requirements.

2.6 INITIAL CHECKOUT

This procedure should be used to determine that the B5X is operational. The procedure assumes that the drive is installed and I/O cable and power are connected.

1. Verify that the spindle rotates.
2. Load the diskette and apply a head load command to the drive. Check that head load solenoid actuates and indicator lights on front panel. (Select proper device address).
3. Apply stepping and out direction commands to the unit. Verify that the actuator steps as commanded.
4. Remove all command signals, turn power off and return diskette to its storage.

SECTION 3

3.0 INTERFACING REQUIREMENTS

Communication between the host system and the Series B5X flexible disk drive is established via two connectors. Connector J1 establishes a communication link for all input/output signals. These signals are TTL compatible. Connector J2 provides DC power to the device.

3.1 INPUT LINES

The input control lines have the following electrical specifications:

True, Logical Zero = $0V \pm 0.4V$ @ $I_{in} = 48 \text{ MA (max)}$

False, Logical One = + 2.5 to + 5V (open collector @ $I_{out} = 250 \mu\text{A max}$)

3.1.2 LINE TERMINATION

The signal interface used by the Series B5X is of the "bus" or "daisy chain" type. Only one Series B5X is logically connected to the interface at any one given time. All input signals are terminated directly by a 150 ohm resistor network. Device selection is achieved by appropriately programming the shunt to the desired device address. In a daisy chain configuration only the last device in the daisy chain requires the terminating network, while in a star configuration every device should be terminated. The programmable shunt is AMP P/N 435704-8. For convenience the programmable shunt could be replaced by a dip switch, AMP P/N 435166-5.

The seven lines channeled through the shunt are:

	<u>Designator</u>	<u>Pins</u>
1. Head Solenoid	T1	1 - 14
2. Drive Select 1	T2	2 - 13
3. Drive Select 2	T3	3 - 12
4. Drive Select 3	T4	4 - 11
5. MUX (Grounded)	T5	5 - 10
6. Spare	T6	6 - 9
7. Motor On	T7	7 - 8

3.1.3 DRIVE SELECT 1 TO 3

In a single drive configuration this input will load the Read/Write head against the media. For a multi-drive configuration the trace "MUX" should be cut to allow multiplexing of I/O lines. In such a configuration only the device selected will respond to commands from the host system. After the desired device is selected, allow a 35 msec delay before initiating a read (see figure 3). A seek to another track location can occur 0.3 msec after drive select.

3.1.4 MOTOR ON

This input is provided to extend the life of the DC spindle motor. The motor should be turned off if no activity is required of the Series B5X after 10 revolutions of the diskette. A minimum of 1 second is required before performing a read or write after a "Motor On" command is transmitted to the device (see figures 3 and 5).

3.1.5 DIRECTION SELECT

The direction of motion of the Read/Write head is defined by the state of this input line. Together with a pulsed step input line, a logical one defines the direction as out (see figure 2).

3.1.6 STEP

Together with the direction line a single pulse on this input will move the Read/Write head one cylinder in or out, dependent on the state of the direction line. The motion of the head is initiated on the trailing edge of step pulse. A minimum of 0.2 μ s pulse width at a maximum frequency of 200 Hz should be maintained to assure step integrity (see figure 2).

3.1.7 WRITE GATE

When active, this input line permits writing of data.

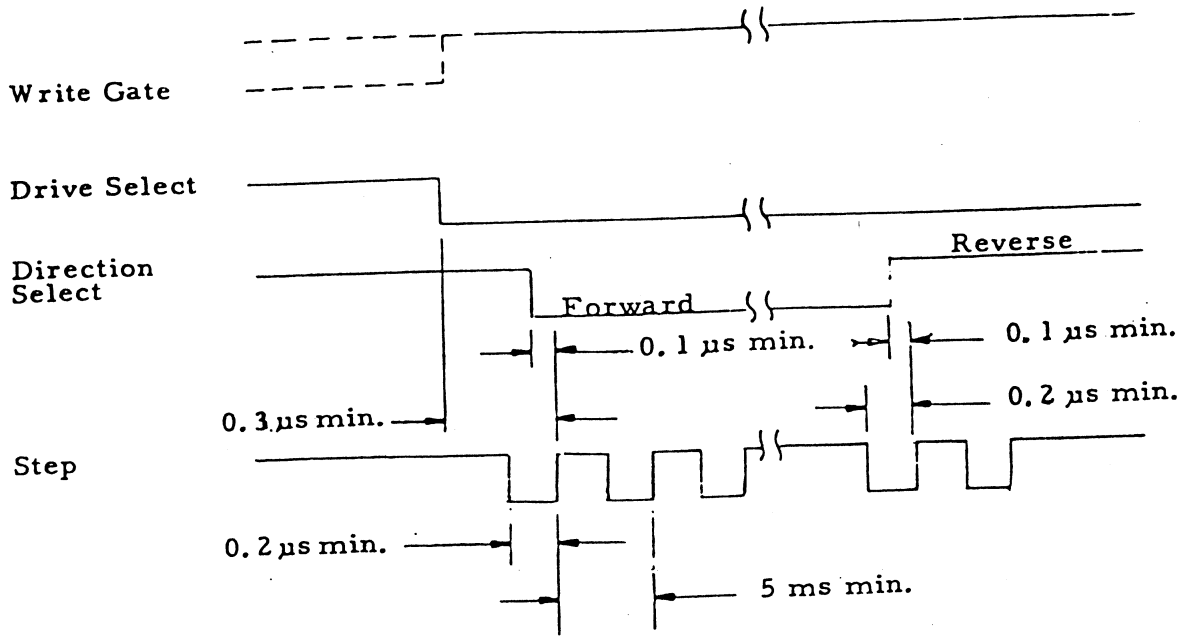

Figure 2 Track Access Timing

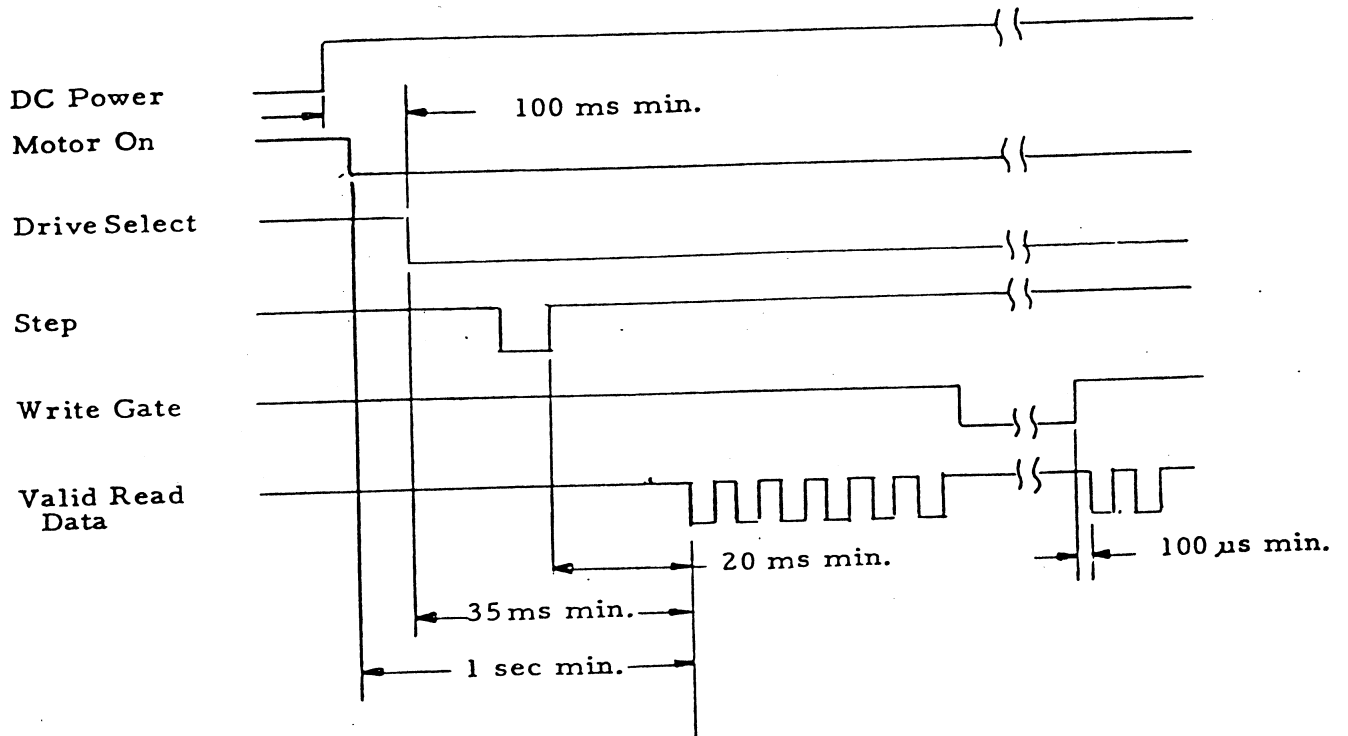

Figure 3 Read Initiate Timing

When inactive, it permits transmitting data to the controller. Allow a minimum of 100 μ sec after dropping write gate before valid data can be decoded (see figures 5 and 7).

3.1.8 WRITE DATA

This input, in conjunction with the write gate input, provides data to be written on the diskette. The frequency of the write oscillator should be held within 0.01% with a pulse width of a minimum of 0.2 μ sec and maximum of 3.5 μ sec. The frequency is dependent upon the encoding scheme used and the density option exercised (see figures 5 and 6).

3.1.9 HEAD SELECT (B52 ONLY)

This input is used to select either the upper or lower head. A 35 μ sec delay should be allowed for the read amp to recover after a head select event occurs. Only then will valid data be present.

3.1.10 DRIVE SELECT 4 (OPTIONAL FEATURE)

This optional input when exercised, allows selection on the fourth device in a daisy or star configuration.

3.2 OUTPUT LINES

The control output signals are driven with an open collector output stage capable of sinking a maximum of 40 MA at logical zero as true state with maximum voltage of 0.4V measured at the driver. When the line driver is in a logical one or false state, the collector cutoff current is a maximum of 250 microamps.

3.2.1 TRACK 00 (OPTIONAL)

This output, when true, indicates that the Read/Write heads are located over track 00.

3.2.3 INDEX/SECTOR

Once every revolution, a pulse is transmitted to the controller indicating the beginning of a track only if a single holed diskette is used. If multi-holed media is used in conjunction with index, sector pulses (10, 16) will also be transmitted to the host system. Leading edge of sector to leading edge of index is 6.25 msec \pm .07 msec (see figures 8 and 9).

3.2.4 WRITE PROTECT

This interface signal is provided by the drive to give the user an indication that a write protected or read only diskette has been installed. This output is a logical zero when the diskette is not write protected.

3.2.5 READ DATA

This output represents digitized data as detected by the drive electronics. Information transmitted will be in the encoding scheme used. Pulse width of both clock and data bits will be 1 μ sec \pm 350 nsec. Maximum bit shift for a clock is \pm 800 nsec while that for data \pm 400 nsec from their nominal bit positions (see figure 4).

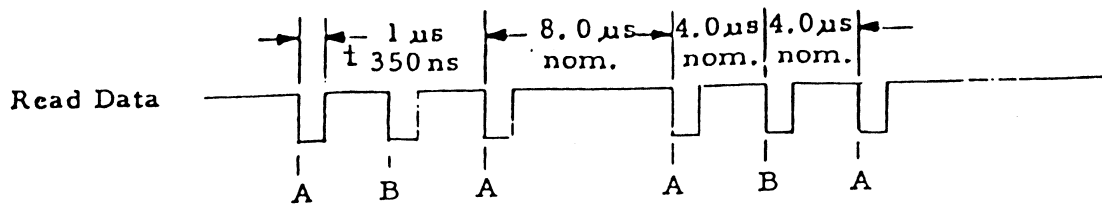

A = Leading Edge of Bit May Be ± 800 ns From its Nominal Position
 B = Leading Edge of Bit May Be ± 400 ns From its Nominal Position

Figure 4 Read Signal Timing

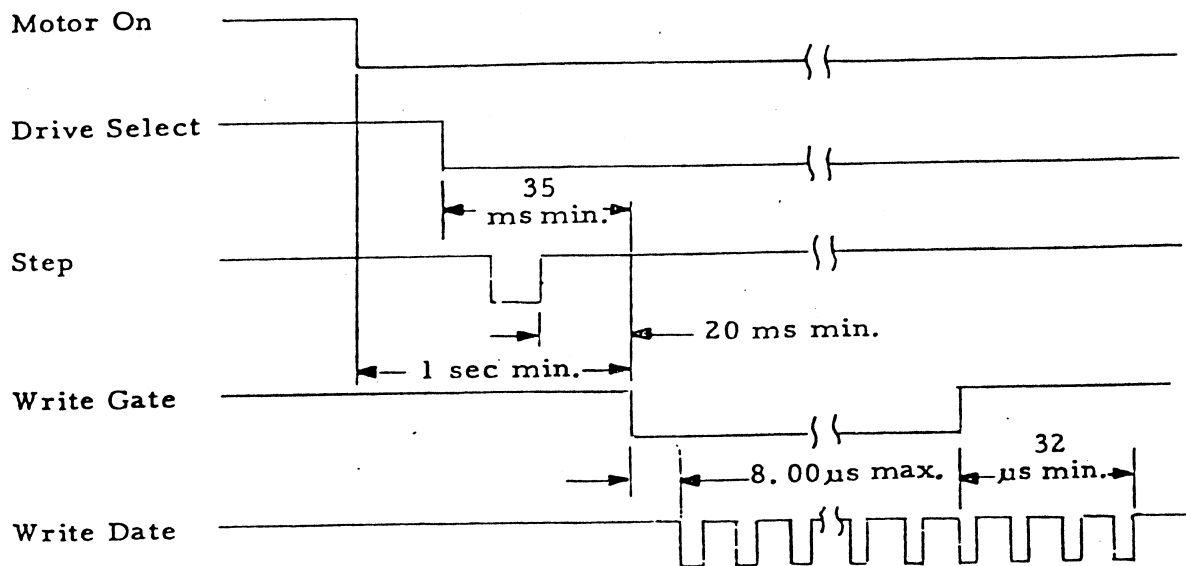

Figure 5 Write Initiate Timing

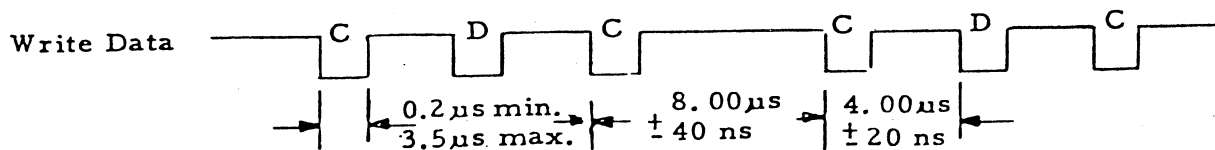

Figure 6 Write Data Timing

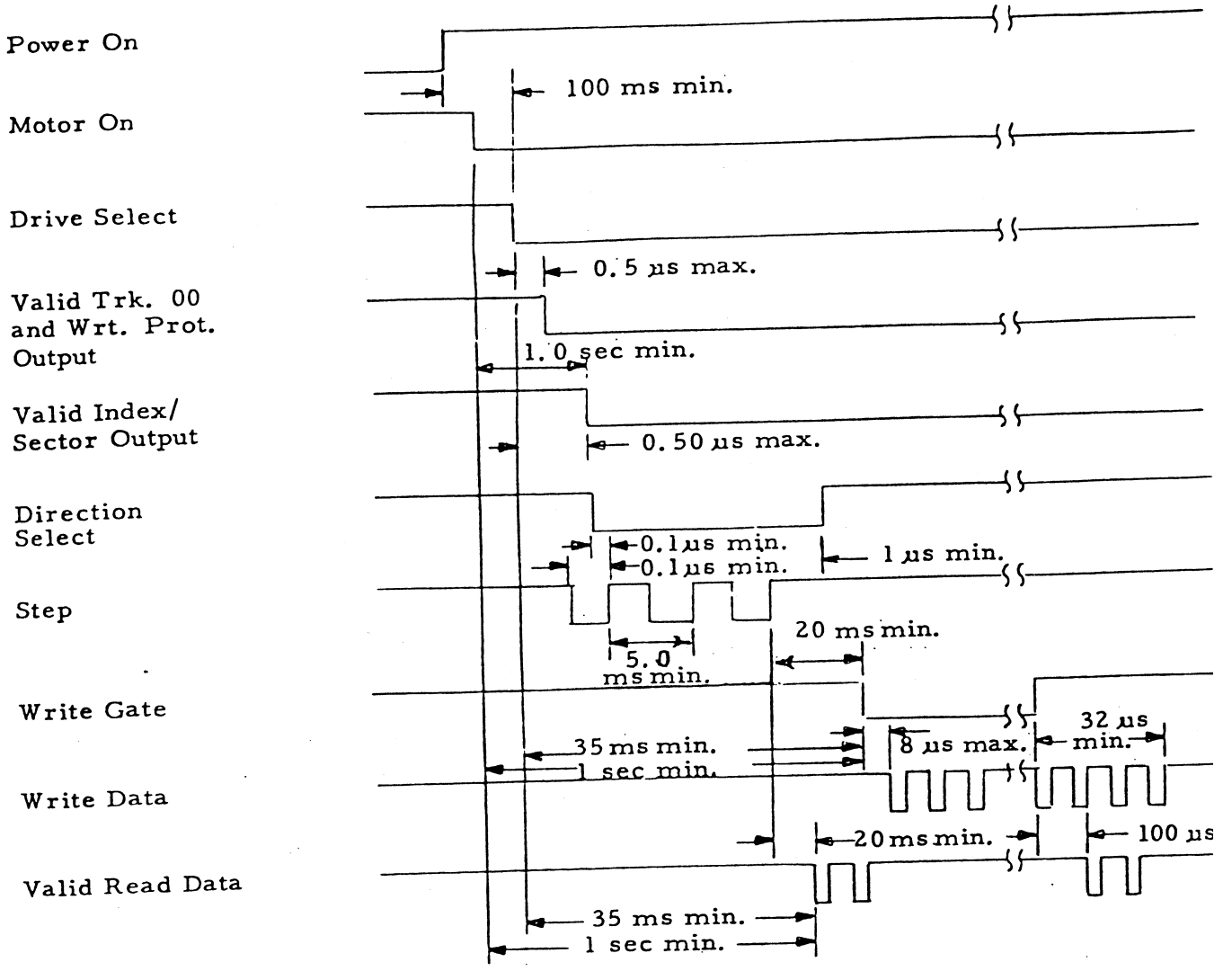

Figure 7 General Control and Data Timing Requirements

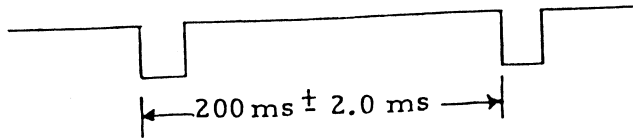

Figure 8 Index Sector Timing (Soft Sector)

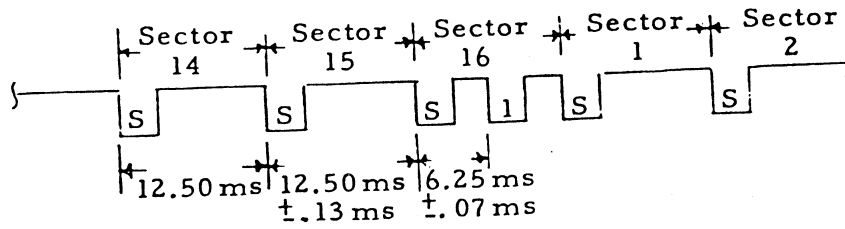
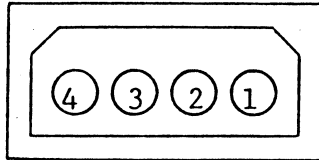

Figure 9 Index Sector Timing (Hard Sector)

3.3 CONNECTOR J2

The DC power connector is located on the non-component side of the printed circuit board. The recommended mating connector is AMP P/N 1-480424-0 using AMP pins P/N 60619-1.



- Pin 1 +12V DC
- Pin 2 12V Return
- Pin 3 5V Return
- Pin 4 +5V DC

Figure 10

3.4 CONNECTOR J1

Connection to J1 is through a 34 pin PCB edge connector. Even numbered pins are located on the component side while odd numbered pins are located on the solder side. A key slot is provided between pins 4 and 6. The recommended connector is 3M Scotchflex P/N 3463-001 or AMP P/N 583717-5 using AMP contacts P/N 1-583616-1.

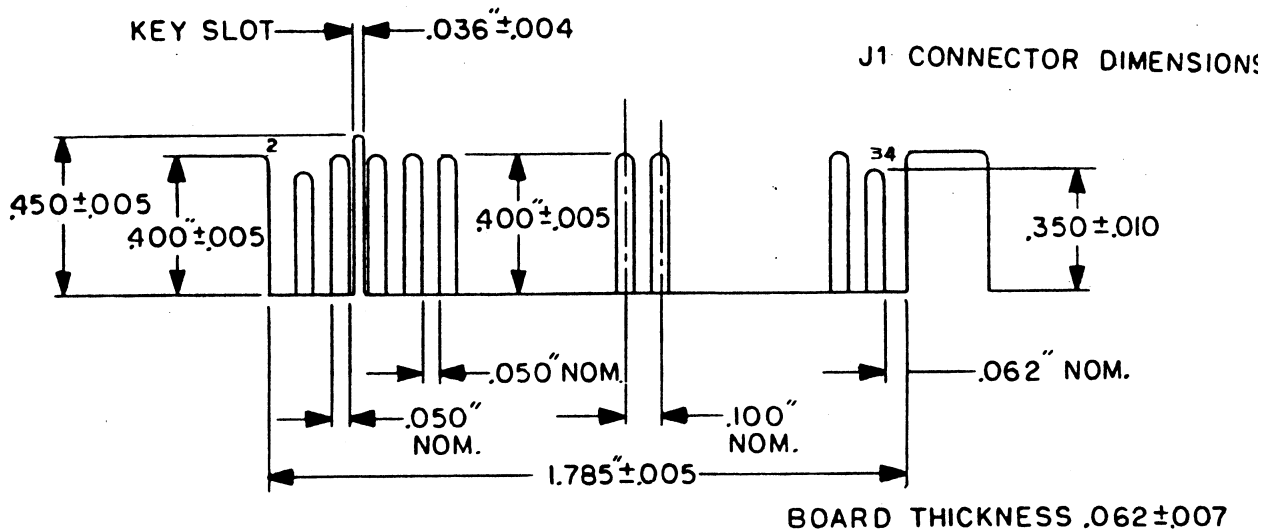
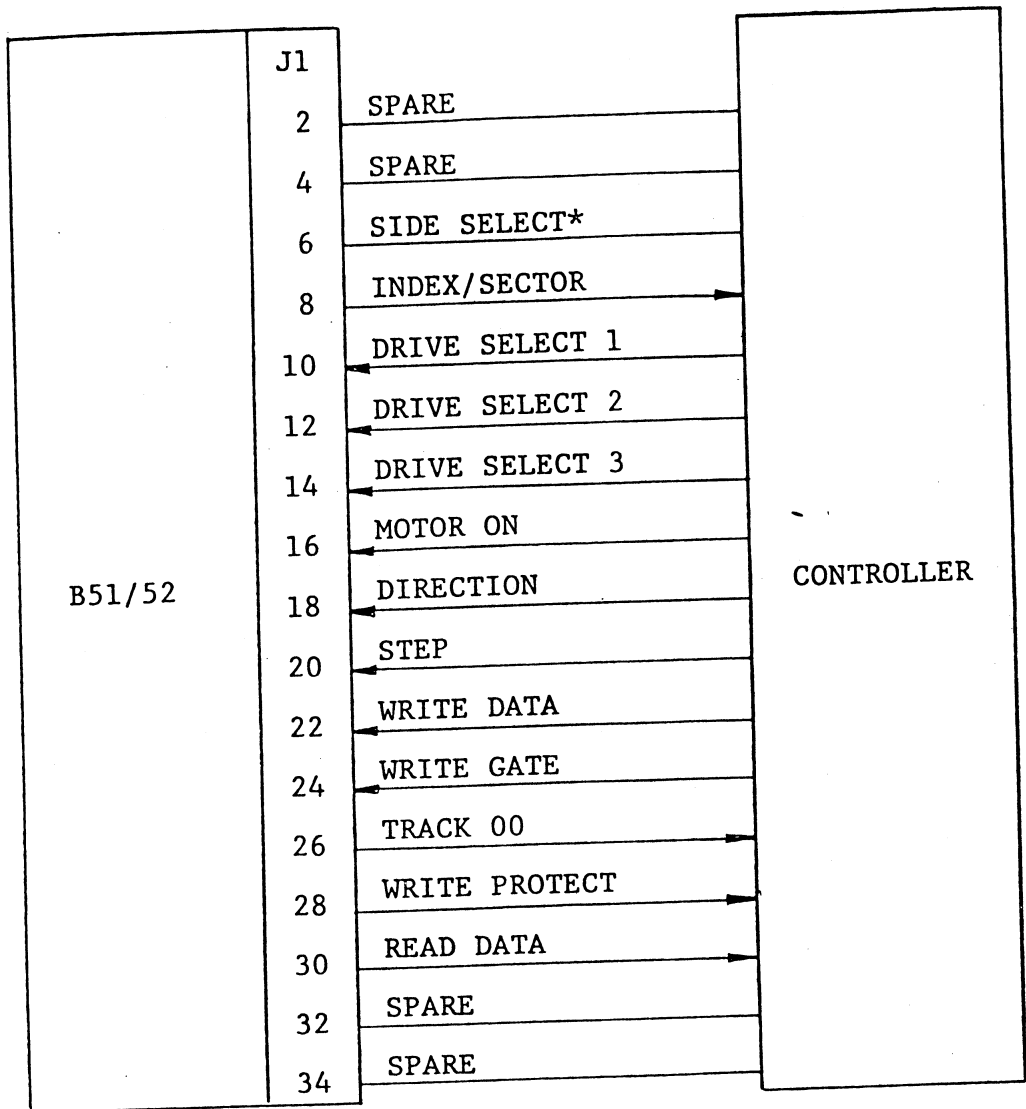

Figure 11



ODD PINS RETURN (DC GROUND)
 * B52 ONLY

POWER

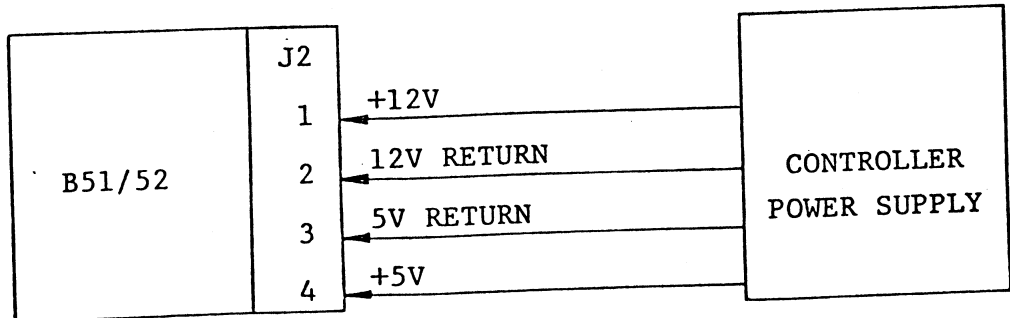

Figure 12 Interface Signals - B51/52

Head Solenoid	1
Drive Select 1	2 Shunt
Drive Select 2	3
Drive Select 3	4
MUX	5
Spare	6
Motor On	7

Figure 13 Shunt Configuration

Recommended Connectors - P1

TABLE 3-1

TYPE OF CABLE	MANUFACTURER	CONNECTOR P/N	CONTACT P/N
Twisted Pair, 26	AMP	583717-S	1-583616-1
Flat Cable	3M "Scotchflex"	3463-0001	N.A.

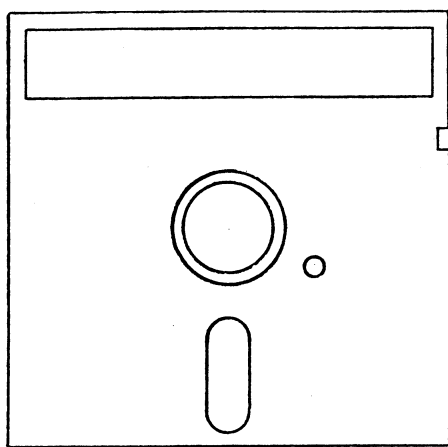

Unprotected

Write
Protect
Notch

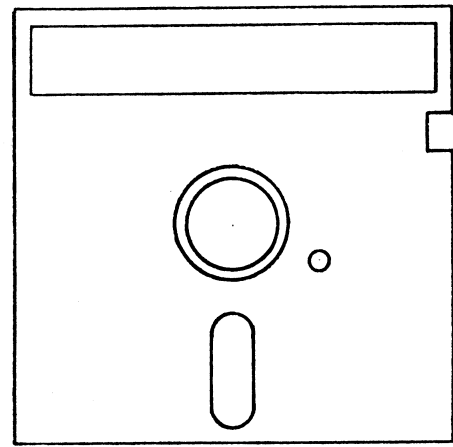

Write Protected

Write
Protect
Tab

Figure 14 Write Protect Option

SECTION 4

4.0 OPERATION

4.1 GENERAL

The B5X is under direct control of the interface and power sources. No special start-up procedures are necessary.

4.2 OPERATING INSTRUCTIONS

Secure both power and I/O connector prior to disk loading.

4.2.1 FLEXIBLE DISKETTE LOADING

- (a) Apply DC power to drive.
- (b) Open drive door by pushing door latch.
- (c) Remove diskette from its storage envelope and insert in the drive. The index hole must be on the left side of the jacket and the label on the right towards the door (see figure 15).
- (d) Close door by pushing door down until latch has been detented and is securing the door.

4.2.2 FLEXIBLE DISKETTE REMOVAL

- (a) Open the drive door; the flexible diskette will automatically be ejected to a position where it can be easily removed.
- (b) Always store the diskette in its storage envelope in order to maintain the highest data integrity.
- (c) Close drive door.

4.3 DISKETTE HANDLING RECOMMENDATIONS

Since the recorded diskette contains vital information, reasonable care should be exercised in its handling. Longer diskette life and trouble free operation will result if the following recommendations are followed:

1. Do not use a writing device which deposits flakes (i.e., lead or grease pencils) when writing on diskette jacket label.

2. Do not fasten paper clips to diskette jacket edges.
3. Do not touch diskette surface exposed by jacket slot.
4. Do not clean diskette in any manner.
5. Keep diskette away from magnetic field and from ferro magnetic materials that may be magnetized
6. Return diskette to envelope when removed from drive.
7. Protect diskette from liquids, dust and metallic substances at all times.
8. Do not exceed the following storage environmental conditions:
 - Temperature - 50°F to 125°F (10°C to 69°C)
 - Relative Humidity - 8 to 80%
 - Maximum Wet Bulb - 85°F (29.4°C)
9. Diskette should be stored when not in use.

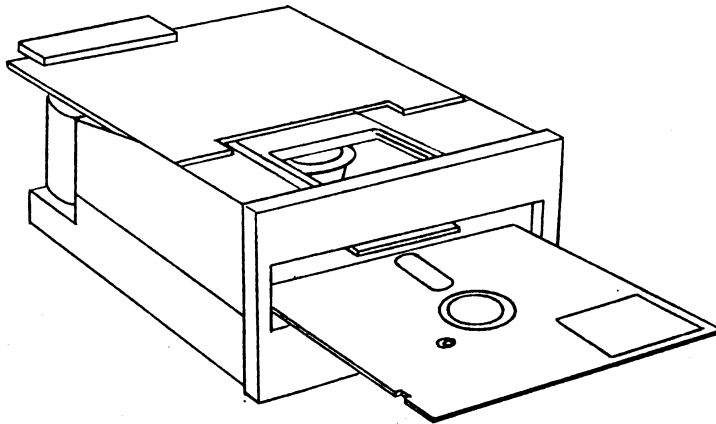

Figure 15 Diskette Orientation

SECTION 5

5.0 THEORY OF OPERATION

5.1 GENERAL

The basic functions of the flexible diskette drive are to:

1. Receive and generate control signals.
2. Position Read/Write head(s) on selected tracks.
3. Write or read data upon command from controller.

The drive consists of a Diskette Drive Mechanism, Head Positioning Mechanism, Head Load Actuator and Read/Write Head(s), Safety Control, Interface and Read/Write Electronics (see block diagram, section 7).

5.1.1 DISKETTE SPINDLE DRIVE

A DC powered motor rotates the spindle via a belt and pulley system at 300 RPM \pm 1%. A clamping hub mechanism moves in conjunction with the door mechanism and precisely clamps the diskette to the spindle hub. The interface line provides the command "Motor On" which starts the motor spinning when true.

5.1.2 HEAD LOAD ACTUATOR

The Read/Write heads are mounted on a band-driven carriage. In the case of the single headed version (B51) the diskette is loaded in close proximity to the head by means of a preload spring mechanism and a felt pad. The double headed Model B52 provides a similar loading condition where the second head mounts in place of the felt pad.

5.1.3 HEAD POSITIONING

An electrical stepping motor drives the carriage via a pulley and band-driven system. This provides for accurate and fast positioning of the Read/Write

head(s). When proper commands are received from the host controller, the carriage is positioned accordingly.

5.1.4 SAFETY AND CONTROL ELECTRONICS

All the electronic functions are packaged on one Printed Circuit Board. These functions are as follows:

- (a) Index detector circuits.
- (b) Motor speed control.
- (c) Motor on/off circuits.
- (d) Head-load actuator drives.
- (e) Head-positioning circuits.
- (f) Read/Write amplifier and pulse shaper.
- (g) Track zero sensor circuits.
- (h) Write protect.

5.1.5 READ/WRITE HEAD

The Read/Write head is a ceramic IBM type head which is loaded in direct contact with the media. The head surface has been designed to insure minimum wear and maximum signal levels both to and from the diskette.

The Read/Write head is a single gap head followed by a tunnel erase structure whose function is to erase the areas between the tracks to eliminate any interferences between two adjacent tracks. Thus data integrity is maintained.

5.1.6 STEPPER MOTOR

The Read/Write head carriage assembly is connected to the stepper motor through a unique band-driven mechanism. The stepper motor, which consists of 4 phases, is driven by 4-open collector drivers. When DC power is applied, the drivers are enabled through +5V. Assuming the unit is selected and the

carriage sitting at track 00, the logic will be enabled and phase 4 is selected to provide the power required to maintain track 00. When the direction line is active and stepper pulses applied, the stepper motor will start turning each phase on sequentially. To move the carriage towards the inner tracks (40), the phase sequence is 4, 3, 2, 1. If too many pulses are applied, the end of track sensor will turn on, disabling the logic from further stepper pulses.

5.1.7 WRITE OPERATION

A write operation begins with a write enable command from the host controller. This command simultaneously enables the write data switching drivers. The write data current source disables the read data out, and after 300 micro seconds, enables the erase current. Data applied to the write data input alternately switches the write current through the write drivers to the Read/Write head.

5.1.8 READ OPERATION

Read operation is enabled when the Read/Write head is loaded on the diskette and write gate is not commanded. With write gate not enabled, the diodes CR7 and CR8 are reverse biased and data sensed by the Read/Write head is fed to the read amplifier. This amplified data is filtered, differentiated, and coupled to a combination differential voltage comparator and one-shot multi-vibrator. The output is coupled to a second one shot, providing the output driver with an unseparated serial data stream.

5.1.9 INDEX PULSE GENERATION

The beginning of each track is indicated by an index pulse. The diskette rotates between a light source (LED) and a sensor (photo transistor). When the

index hole in the diskette passes over the light source, light is detected by the sensor. The sensor output is amplified and transmitted to the host controller as the index pulse.

SECTION 6

6.0 ERROR RECOVERY

6.1 SEEK ERRORS

Unless the stepping rate of 5 msec is exceeded, seek errors rarely occur. However, in the case of a seek error, recalibration of track location is achieved by issuing repetitive step and direction commands to the drive until the track 00 status is received.

6.2 WRITE ERRORS

In order to assure data integrity, a read after write should always occur. If the data cannot be recovered within 4 read retries, it is recommended that the track be labelled defective and a different track (sector) assigned. If more than 2 tracks prove defective, discard the diskette.

6.3 READ ERRORS

If the read after write scheme is followed as described in the previous paragraph, only soft errors are most likely to occur. A soft error is defined as a read error which can be recovered in less than 10 retries. However, if the read error cannot be recovered within 10 retries, step the carriage one step away from the track in the same direction previously moved and then step back. If the data cannot be recovered, the error is not recoverable.

SECTION 7 BLOCK DIAGRAM

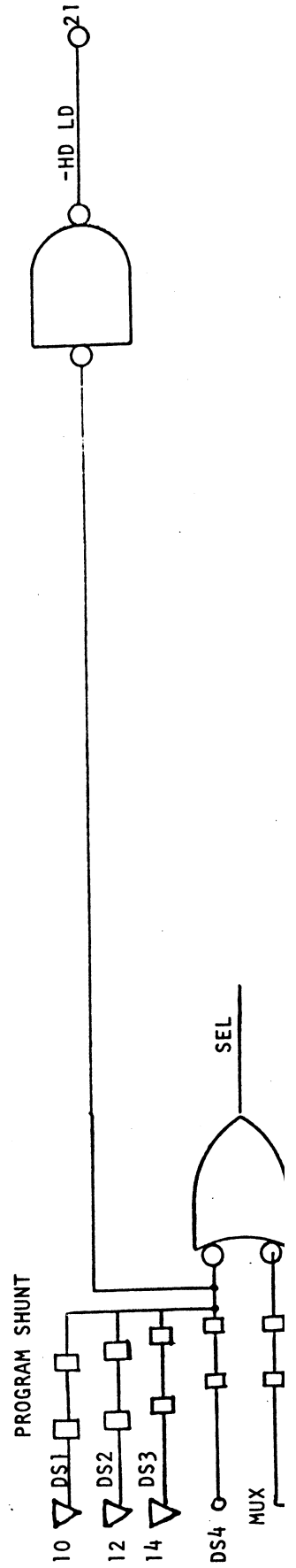
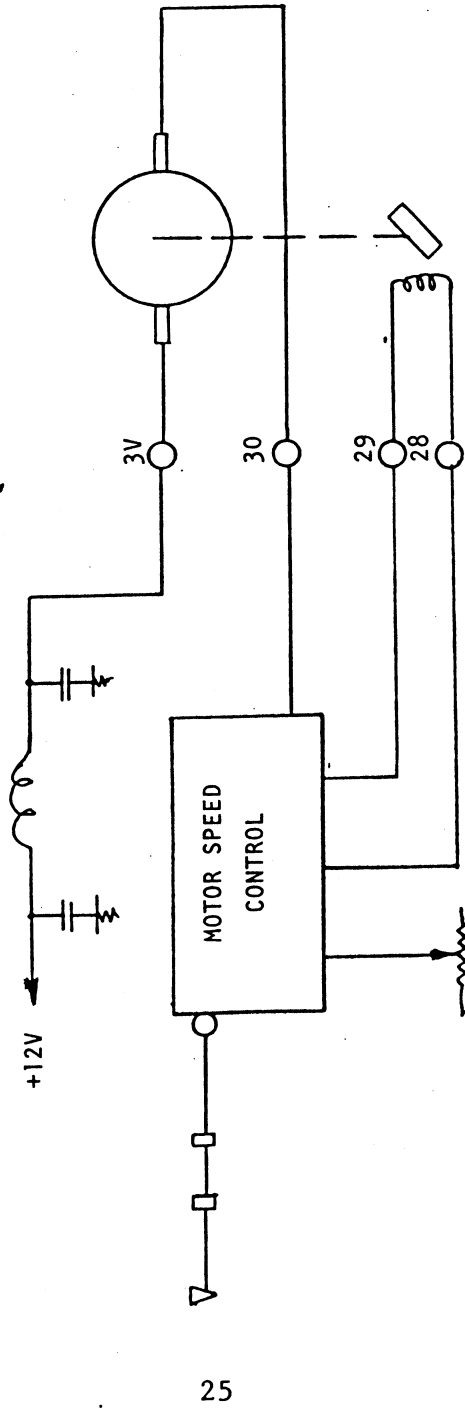
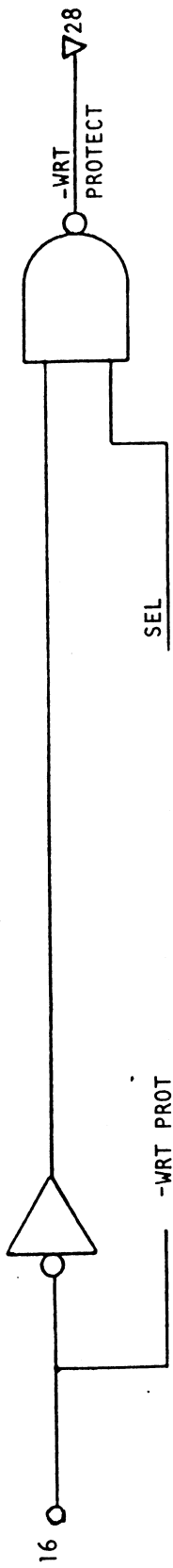

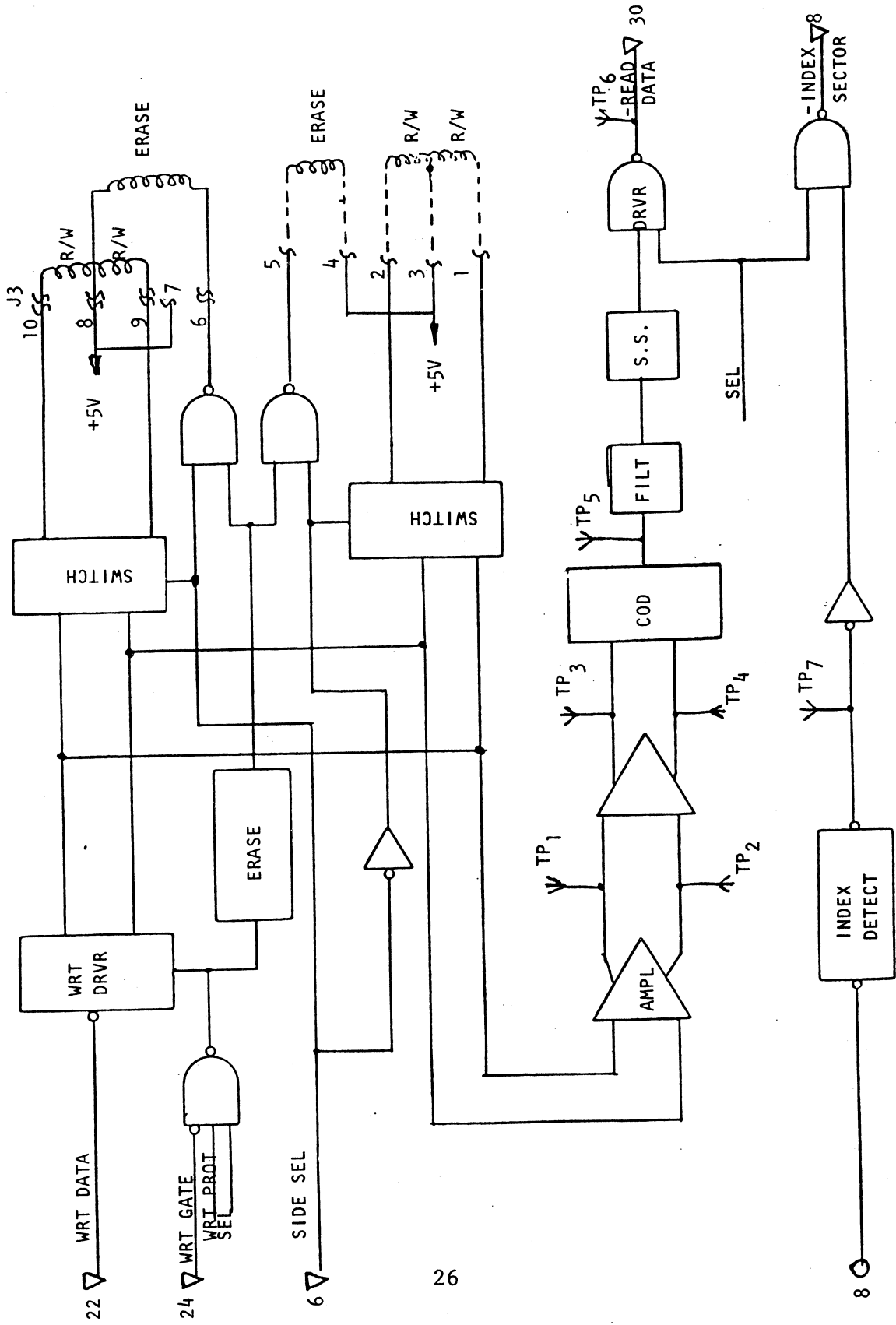

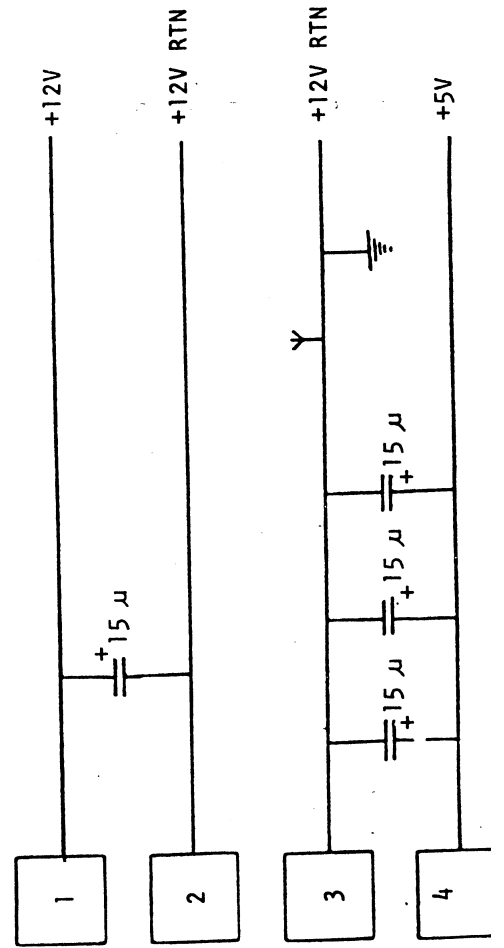
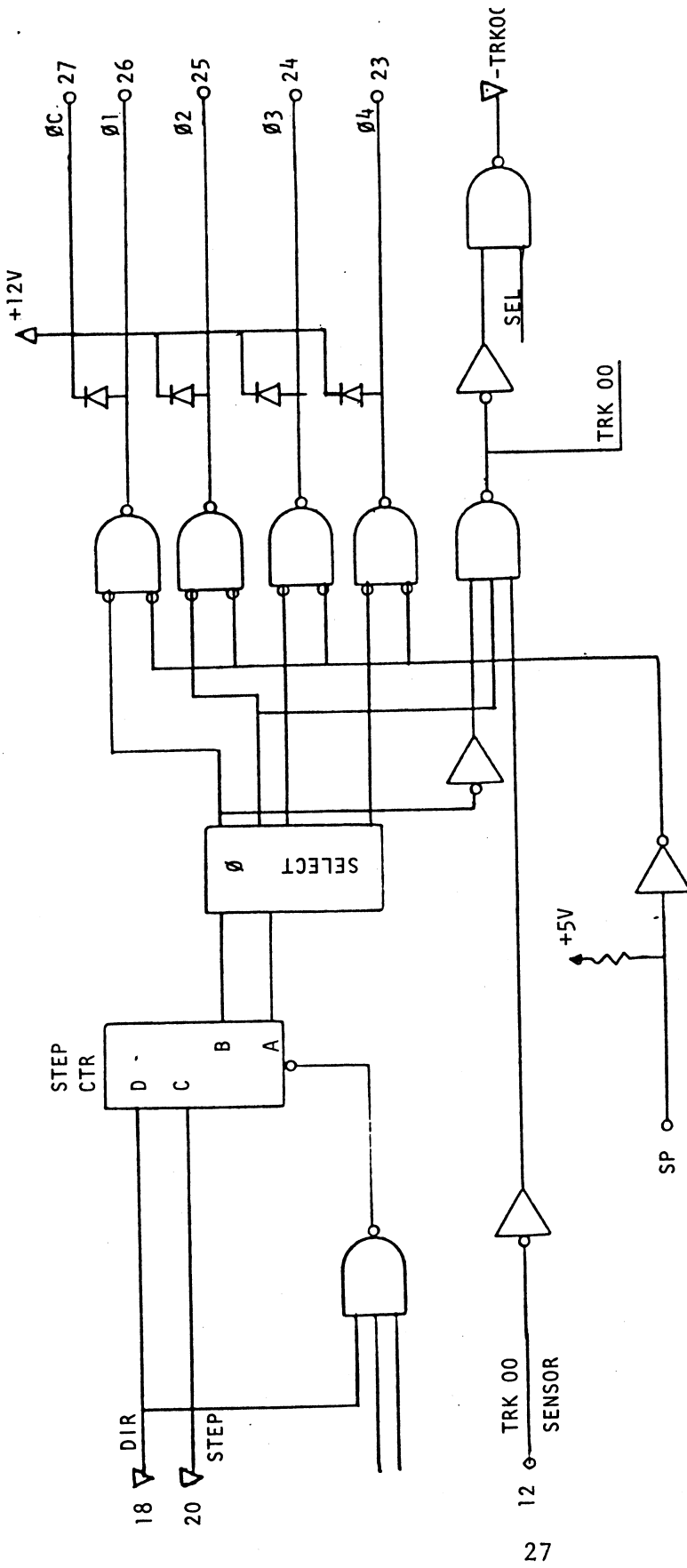

NOTES
 ▽ J1
 ○ J2
 □ J3

SECTION 8

8.0 MAINTENANCE

The only recommended maintenance, which will ensure optimum performance, is periodic cleaning of the Read/Write head(s) and inspection of the load pad.

In case of repair, the following section describes the required adjustment procedures.

8.1 CLEANING READ/WRITE HEAD

Inspect the load pad (or top head) for excessive oxide, using a dental mirror.

NOTE: Do not move the upper arm any further than is allowed by the door in its open position.

To clean the heads, use a lint-free cloth or cotton swab moistened with 91% Isopropyl alcohol. Wipe the head(s) carefully to remove all accumulated oxide and dirt. Dry the head(s) using a lint free cloth.

8.2 ADJUSTMENT PROCEDURES

The following adjustments are required if the parts are being changed due to malfunction. It is recommended, in order to ensure data commonality between drives, that a master alignment diskette be kept and alignment, on a routine basis, be verified to the master.

8.2.1 RADIAL CE ALIGNMENT

- A. Apply necessary power and I/O controls to the drive.
- B. Insert a CE alignment diskette (MPI Part No. 1-42000-001) and close the door.
- C. Synch osc. scope on leading edge on TP6. Connect two probes differentially to TP1 - TP2. Set channels A - B to 50mV/cm

AC coupled. Ground probes to TP7.

- D. Load head and apply 16 stepping pulses. The carriage should be located around track 16.
- E. With power on, loosen the set screw in the stepper pulley and position the pulley such that the catseye appears on the scope with equal amplitude. Secure the pulley. Command a return to zero and step backout to track 16 to verify proper alignment.

8.2.2 INDEX TO DATA ALIGNMENT

- A. Repeat steps A - E (8.2.1) and then move the head to track 01.
- B. The index sensor clamp screws are located at the bottom of the drive. Loosen the screws and move the sensor such that the scope picture shows a data pattern starting 200 ± 50 microseconds from the trigger point.
- C. Tighten the screws carefully, so no variations in the scope reading occurs.

8.2.3 TRACK 00 SENSOR

- A. Apply necessary power and I/O control to the drive and load head.
- B. Connect osc. scope to J2-12 set trigger to internal/auto.
- C. When the carriage is located over track 00, J2-12 should be on (0.5 volts).
- D. Command one step-in pulse J2-12 should go high (approximately 1.2 volts). Command another step-in pulse so the carriage is positioned at track 02; J2-12 should be fully on (approximately 4.8 volts).

8.2.4 SPEED CONTROL

- A. Apply necessary power I/O control and load head.

- B. Insert diskette and close door.
- C. Turn the drive on its side to get access to the strobe mounted on the spindle pulley.
Adjust R28 until a stable picture is appearing from the strobe.

8.2.5 TRACK 00 END STOP

- A. Apply power and I/O controls and load head.
- B. Command seek to track 00.
- C. Adjust set screw located on the left-hand boss in the rear of the drive to approximately 0.010 inch from the end of the carriage.
Command maximum track seek then return to zero. Assure that carriage does not hit the end stop.

APPENDIX A

SPARE PARTS LIST - MODELS B51/B52

<u>PART NUMBER</u>	<u>DESCRIPTION</u>
3-29000-001	Assembly, PCB B51/B52
2-35003-001	Assembly, Spindle Drive Motor
2-35002-001	Assembly, Stepper Motor
4-35005-001	Assembly, Head Carriage
4-35008-001	Assembly, Carrier
3-35006-001	Assembly, Diskette Guide, Right Spare
4-21013-002	Assembly, Diskette Guide, Left Spare
2-35001-001	Assembly, Index Sensor
2-32002-001	Assembly, Head Load Solenoid
2-27003-001	Band, Stepper Drive
2-32000-001	LED, Status Indicator
2-27011-001	Band/Carriage Mounting Clip
2-27004-001	Belt, Drive